

CANOE POLO-GOAL

NOTES

1. FIX NET TO FRAME WITH PLASTIC CABLE TIES OR EQUIVALENT.

2. BOLT LIST

- MB x 70 LG - 14 OFF
- MB x 110 LG - 2 OFF
- φ2 SPRIN CLIPS - 4 OFF
- MB NYLOC NUTS - 16 OFF
- MB FLAT WASHERS - 16 OFF

NOTE: ALL FASTENERS TO BE STAINLESS STEEL

200 WIDE RED STRIPES
AT 200 SPACING

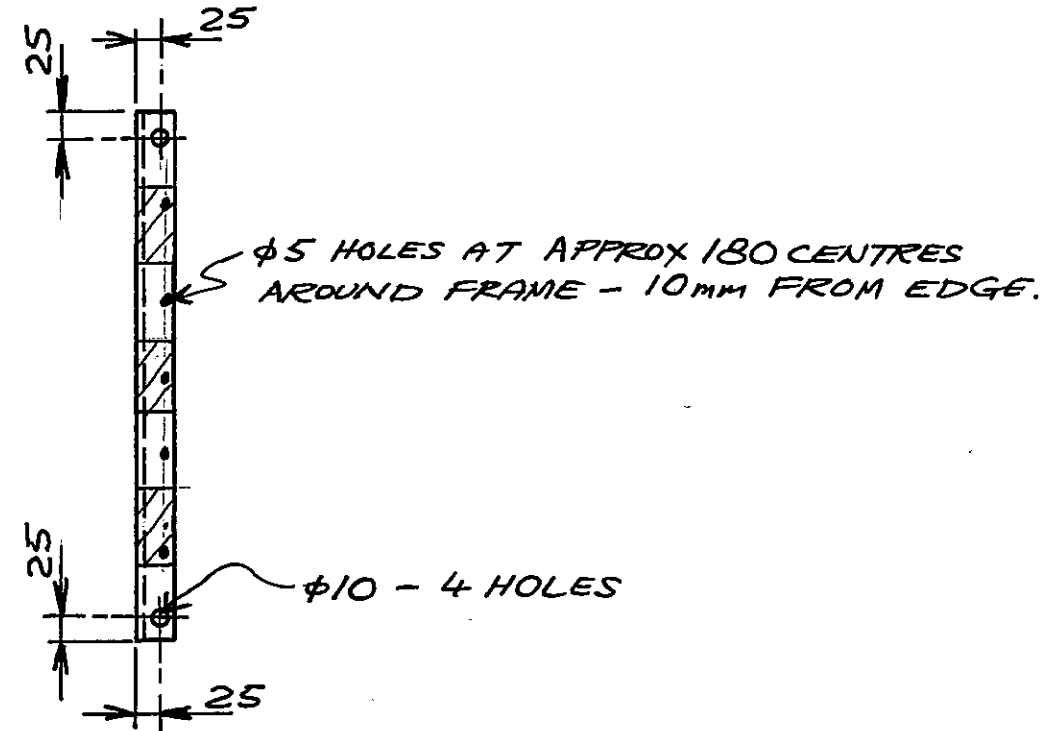
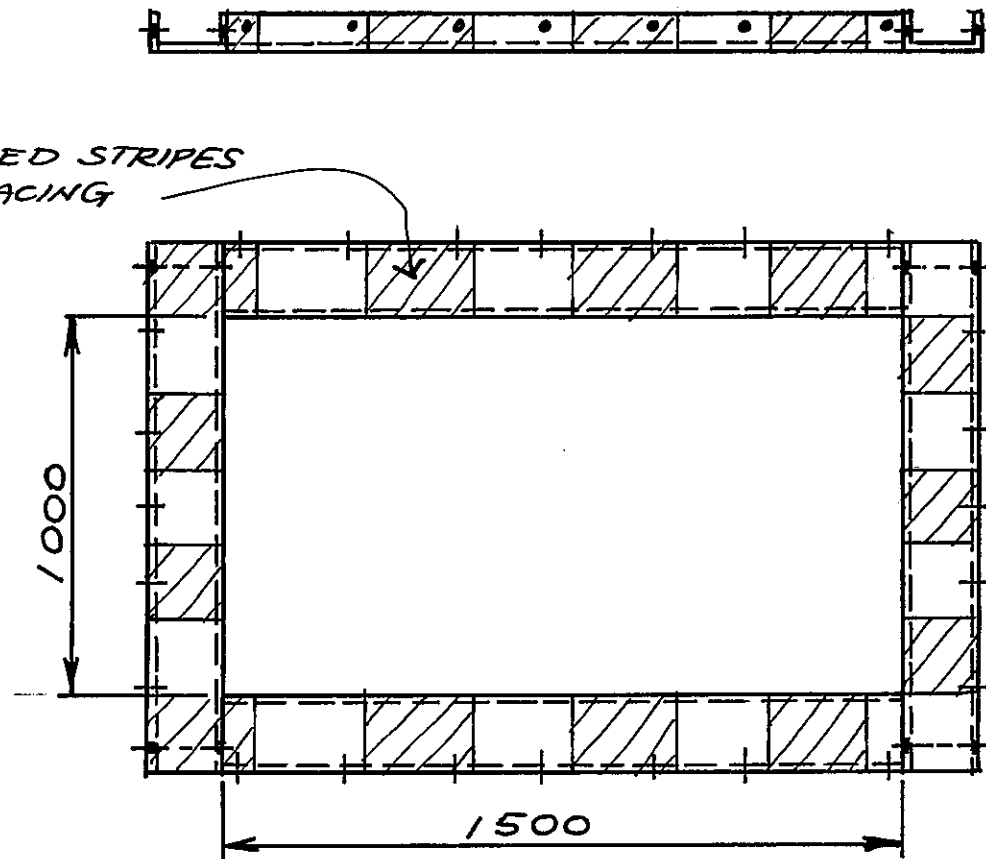

① GOAL - 1 OFF

MATERIAL: 50 x 40 CHANNEL - ALUMINIUM
REMOVE ALL SHARP EDGES AND BURRS

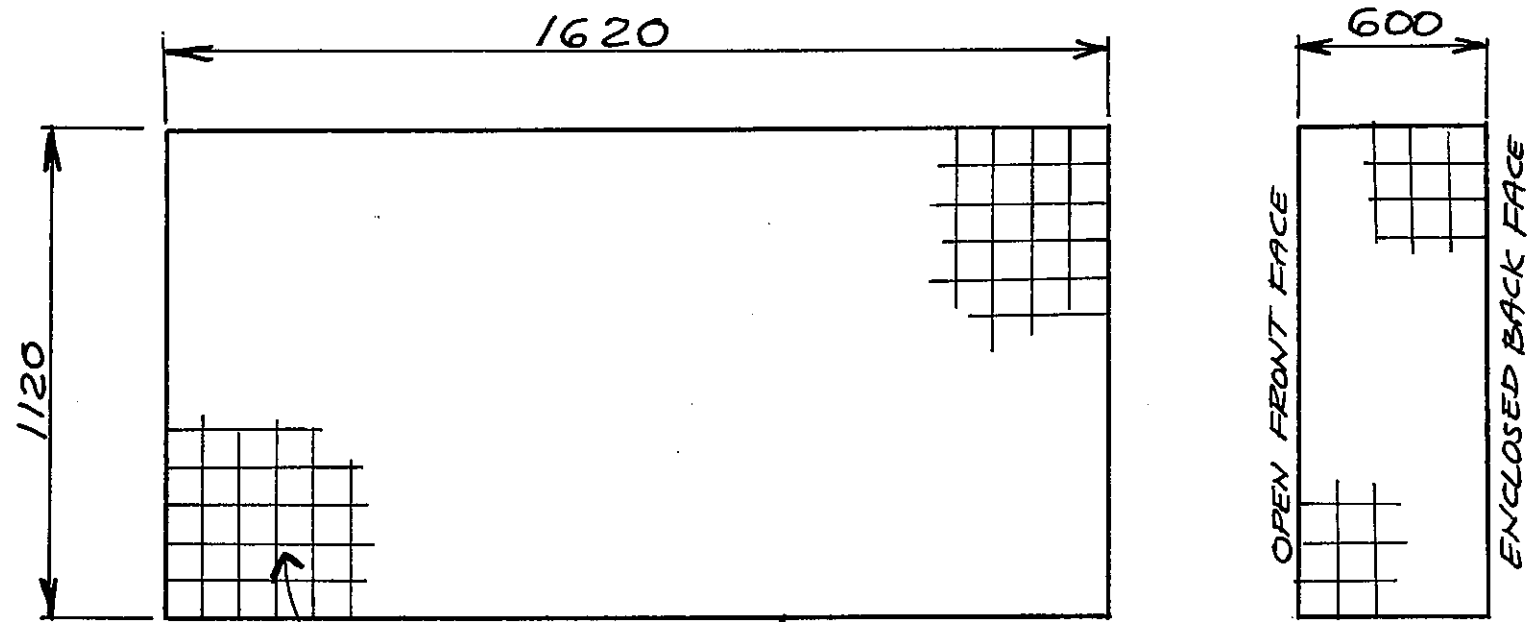

90 x 90 MESH
APPROX ϕ 2 CORD

ALL EDGING TO BE
APPROX ϕ 5 CORD

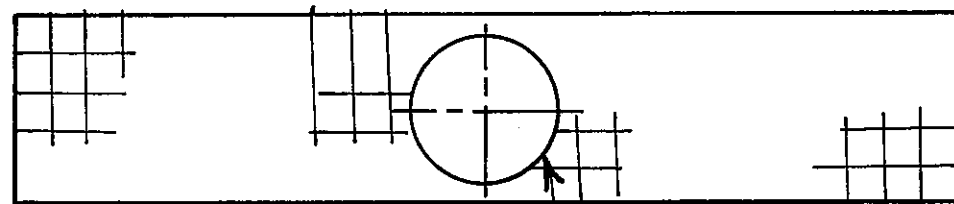

ϕ 500 OPENING IN
BOTTOM OF NET

② NET-10FF
MATERIAL: POLYPROPYLENE CORD
OR SIMILAR

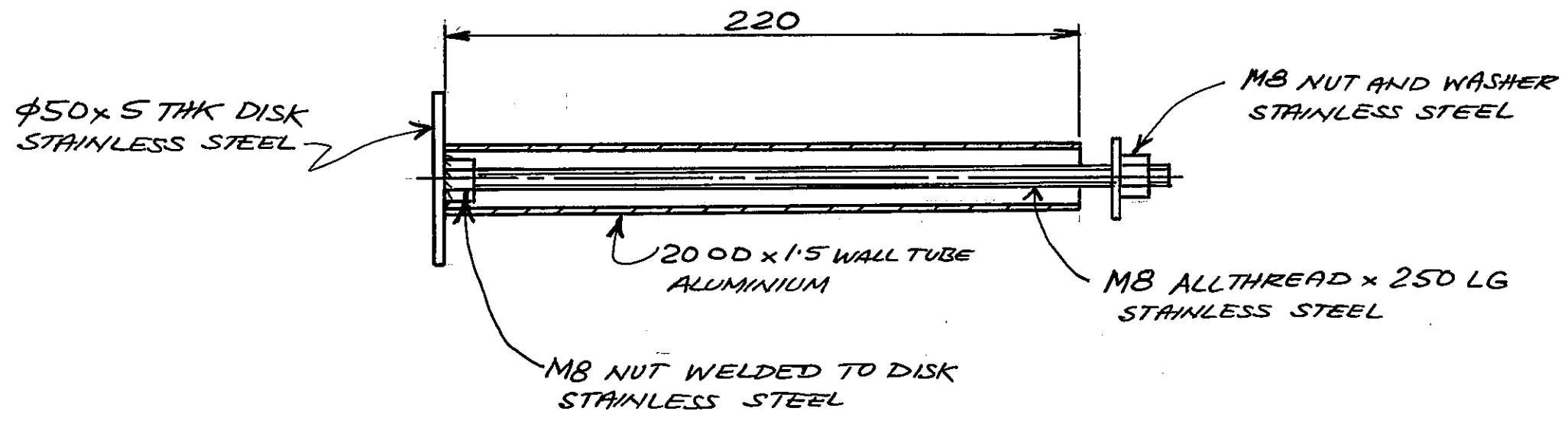

⑫ ALLTHREAD - 10 OFF

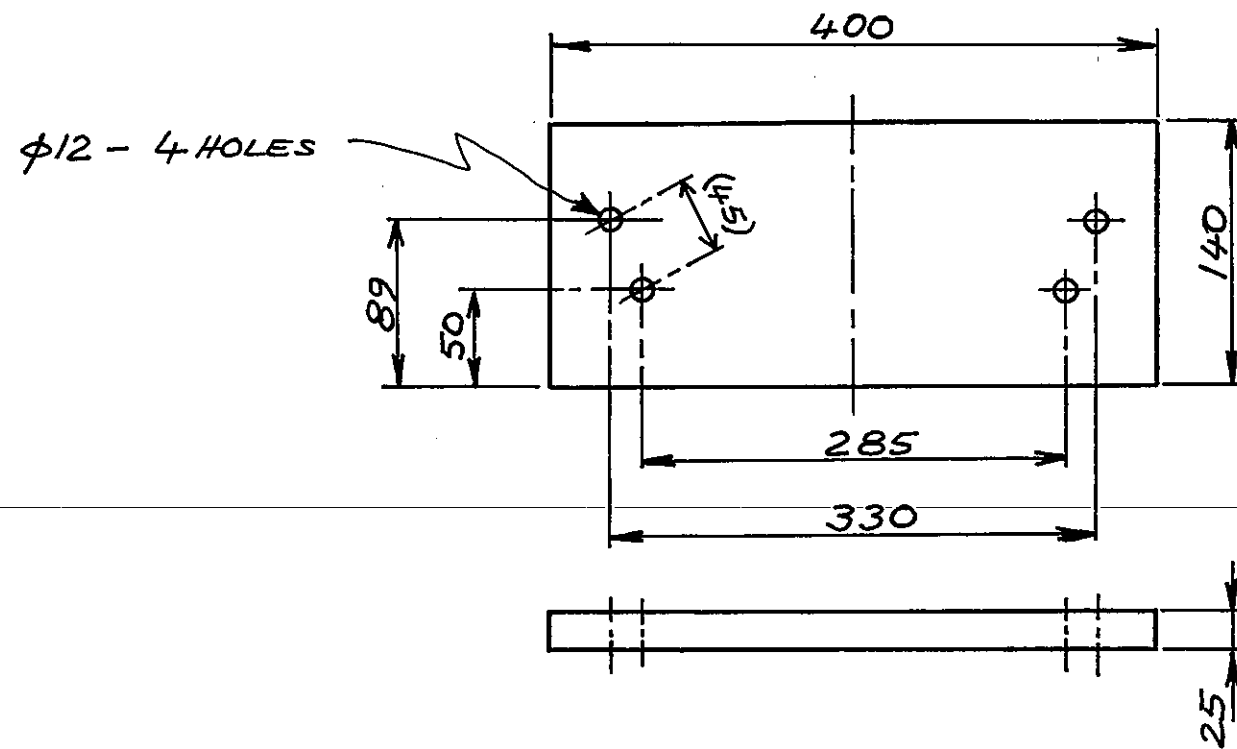

①① COUNTER WEIGHT - 2 OFF

MATERIAL: STEEL - HOT DIP GALVANIZED

REMOVE ALL SHARP EDGES AND BURRS

WEIGHT: APPROX 10kg

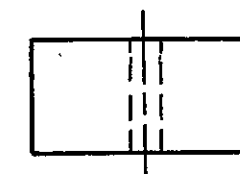
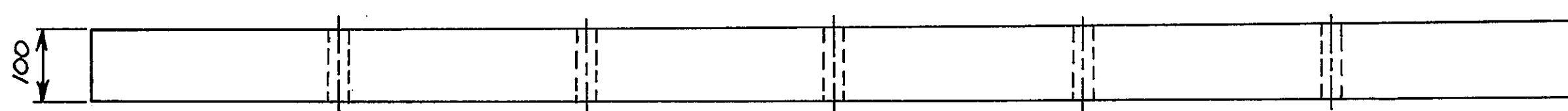
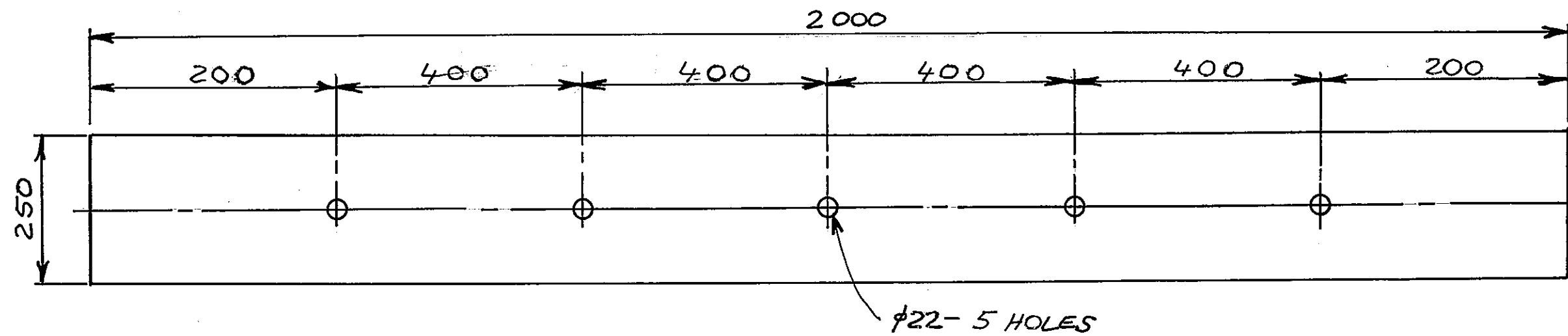

⑩ FLOAT - 4 OFF
MATERIAL: CLOSED CELL FOAM

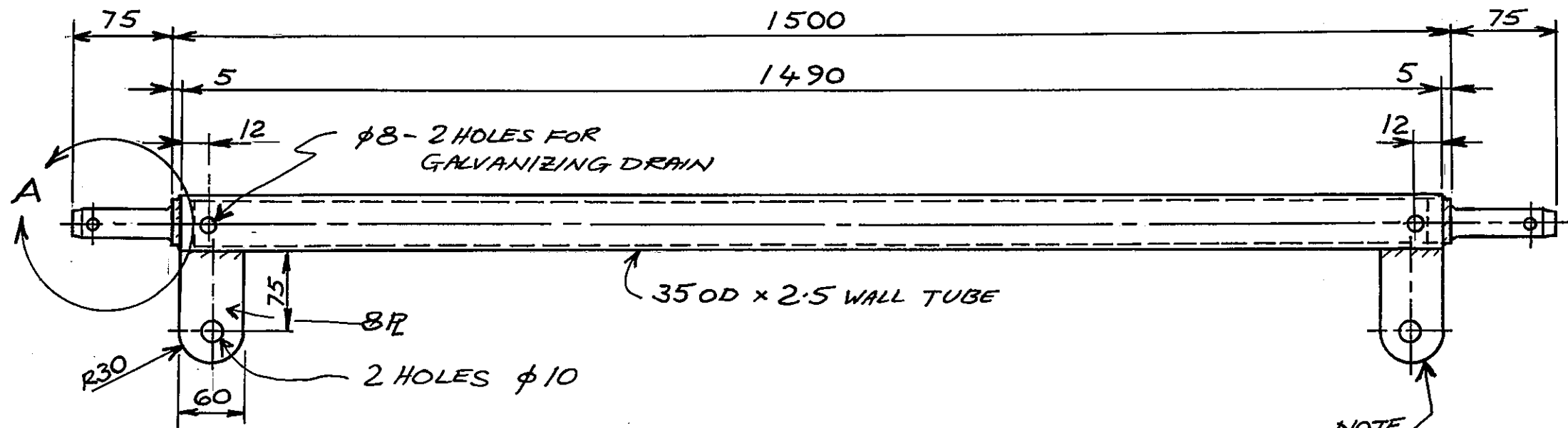

NOTE
THE BOTTOM TIE
DOES NOT HAVE
THE TWO 8R LUGS

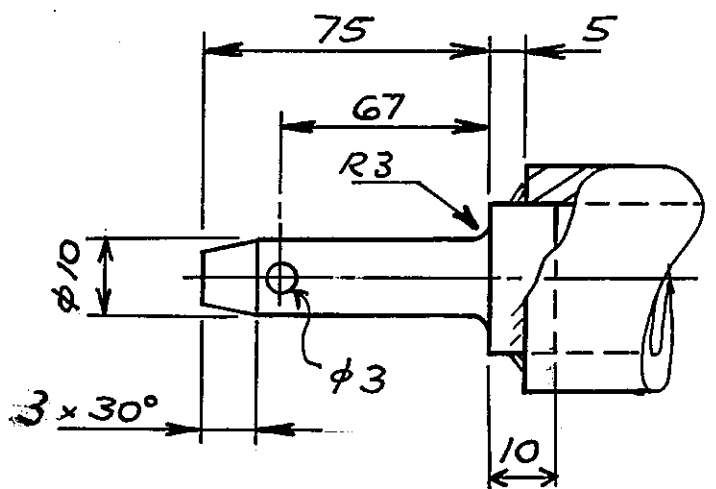

DETAIL A

⑧ TOP TIE - 1 OFF

⑦ BOTTOM TIER - 1 OFF

MATERIAL: STEEL-HOT DIP GALVANISED
REMOVE ALL SHARP EDGES AND BURRS
ALL 5mm FILLET

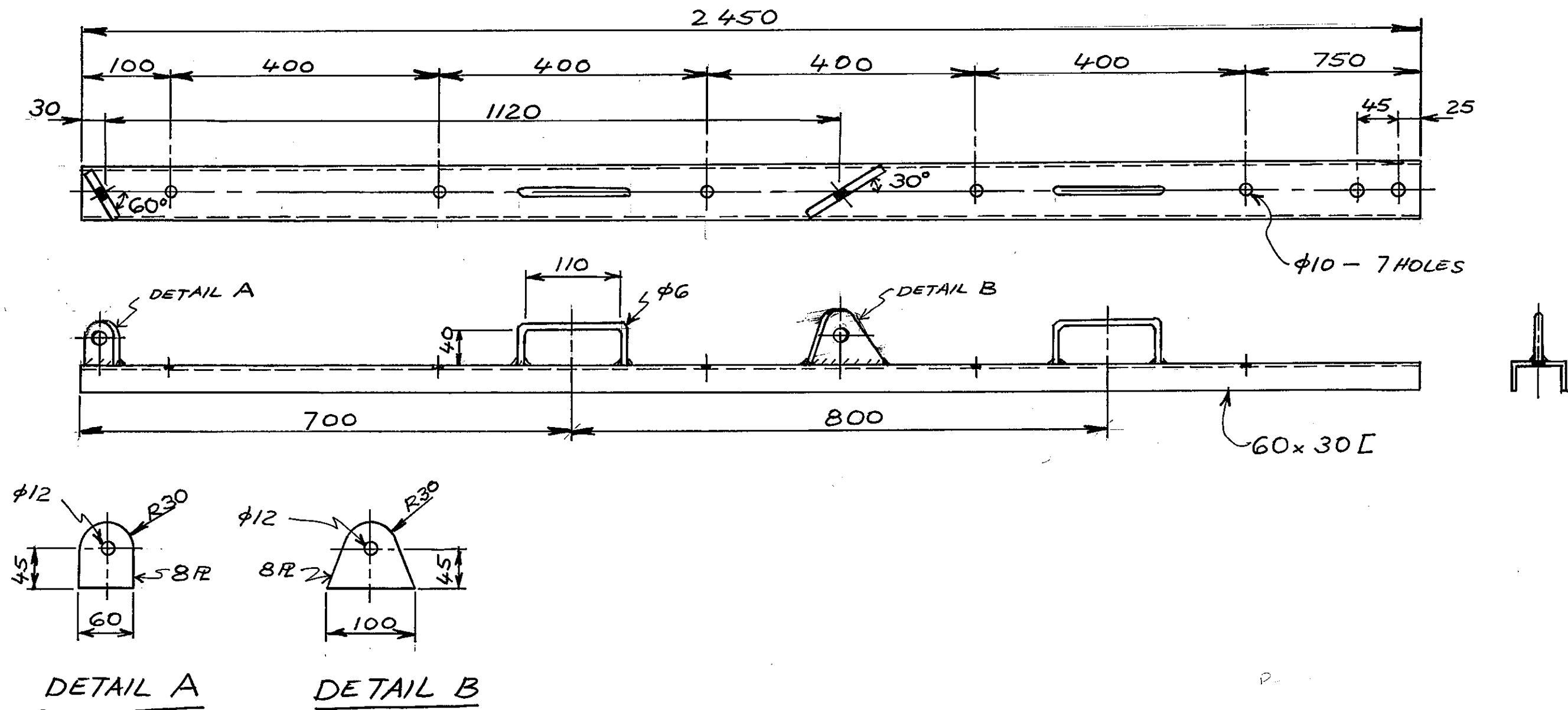

⑨ BASE - 1 OFF AS DRAWN
 - 1 OFF OPPOSITE HAND
 MATERIAL: STEEL

- NOTES:
1. ALL WELDING 6mm FILLETS
 2. REMOVE ALL SHARP EDGES AND BURRS.
 3. HOT DIP GALVANIZE COMPLETED FABRICATION.

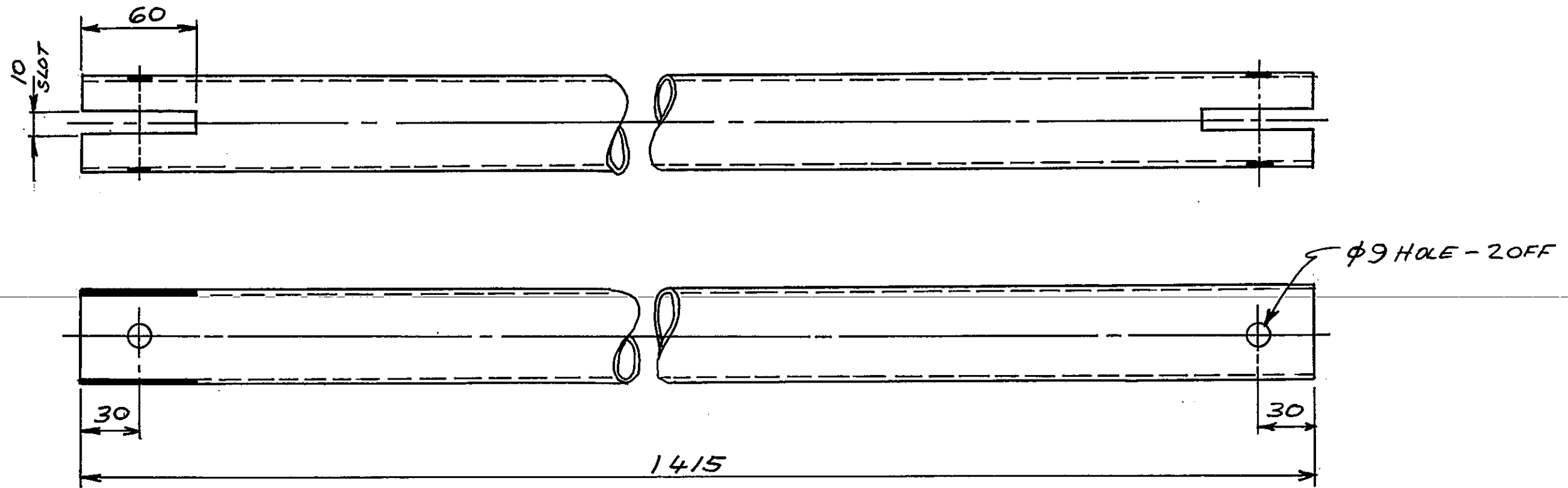

⑥ STRUT - 2 OFF

MATERIAL: 50 OD x 3 WALL ALUMINIUM TUBE

REMOVE ALL SHARP EDGES AND BURRS

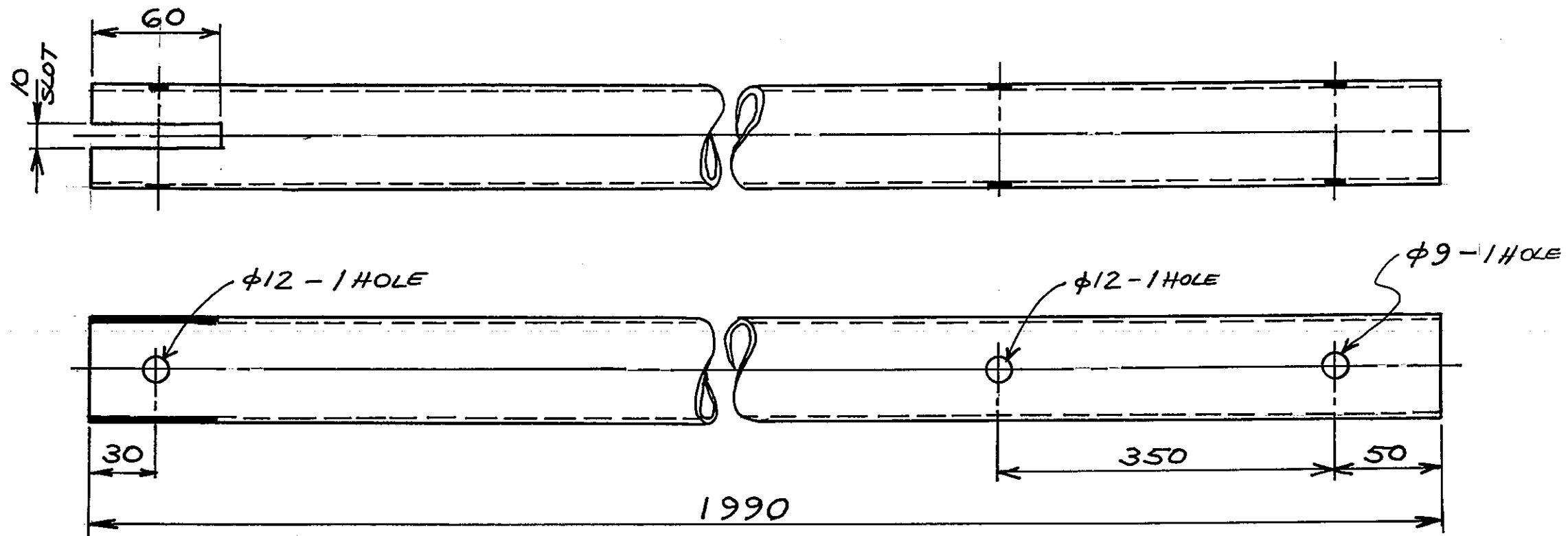

⑤ GOAL SUPPORT - 2 OFF

MATERIAL: 60 OD x 3 WALL ALUMINIUM TUBE
 REMOVE ALL SHARP EDGES AND BURRS

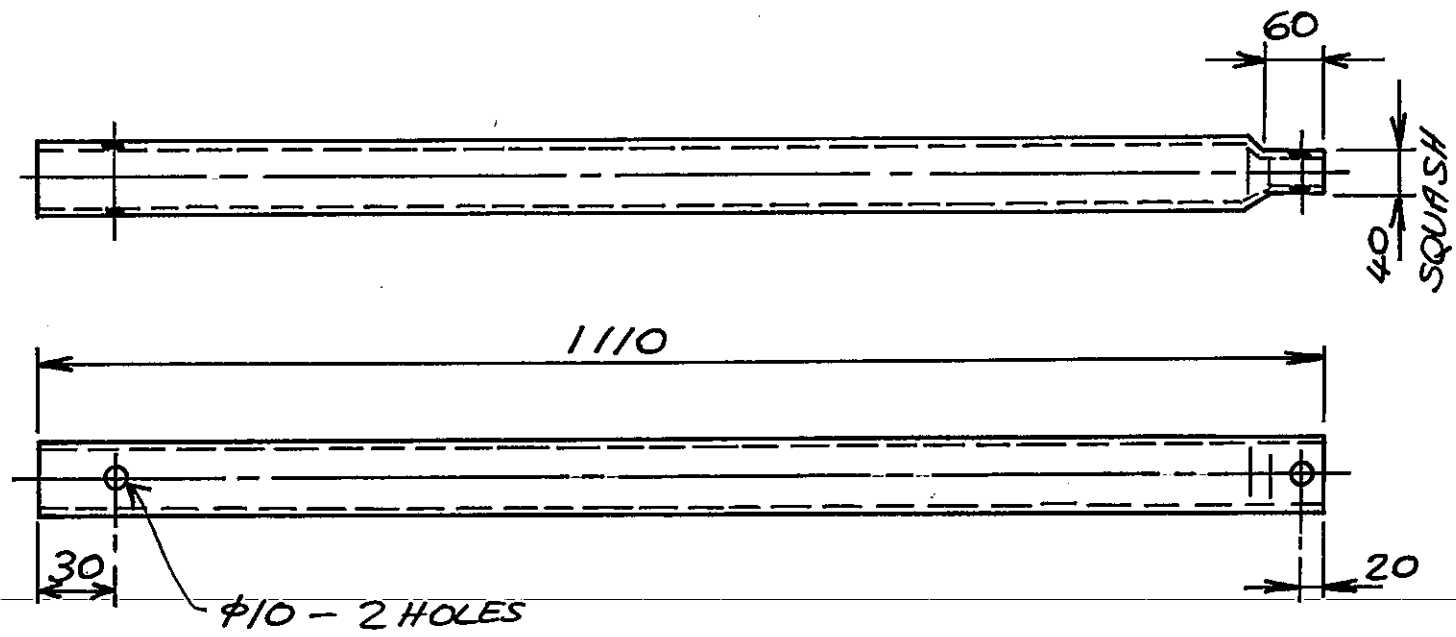

④ BRACE - 2 OFF
MATERIAL: 50 OD x 3 WALL ALUMINIUM TUBE
REMOVE ALL SHARP EDGES AND BURRS

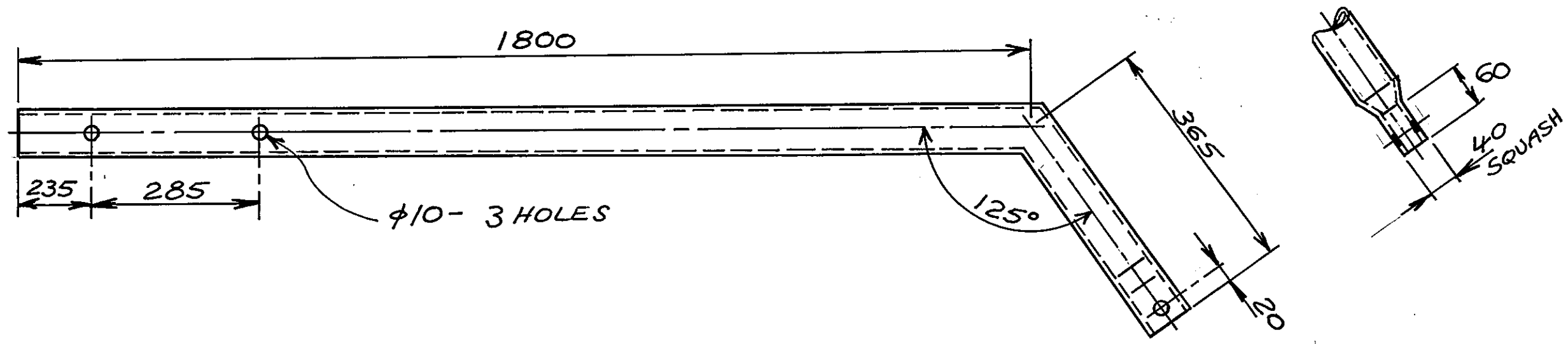

③ GOAL HANGER - 2 OFF
MATERIAL: 50 OD x 3 WALL ALUMINIUM TUBE
REMOVE ALL SHARP EDGES AND BURRS